

# SAFETY STRAPS

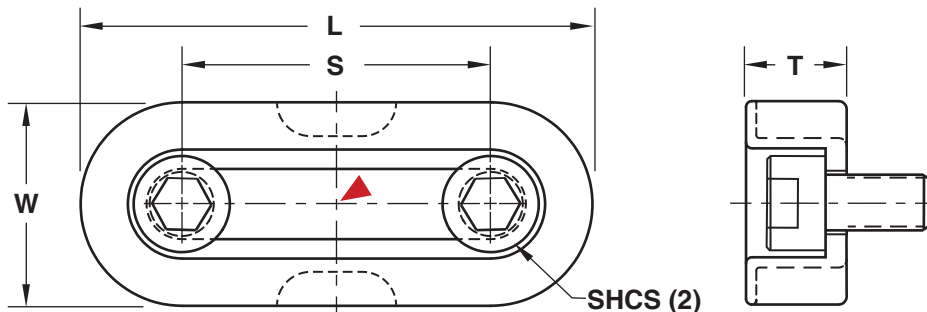

## APPLICATION GUIDELINES

- Secures mold parting lines for transportation, mold setting, and storage.
- Breakaway feature in center of the Safety Strap is engineered to break slightly before the bolts would shear.
- If unintentionally left on the mold in the press, the Safety Strap will be obvious to the operator that it is broken and can easily be replaced. Other straps shear the bolts, which cannot be removed with the mold in the press, creating an unsafe condition when the mold is later removed from the machine.
- Progressive Safety Straps can replace others' mold straps.
- Strength Ratings have a safety factor of two.
- Powder coated OSHA yellow.



**M** 1010 **H** 85 Brinell

CATALOG NUMBER	L	W	T	S	SHCS	STRENGTH RATING (LBS)
<b>SAFT-88</b>	1.62	.75	.37	.88	1/4-20 x 1/2	1,000
<b>SAFT-150</b>	2.50	1.00	.50	1.50	5/16-18 x 5/8	1,500
<b>SAFT-200</b>	3.37	1.37	.75	2.00	1/2-13 x 1	3,000

▶ CAD insertion point

Holo-Krome® screws included.

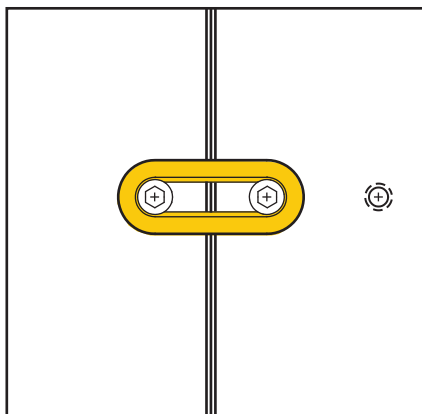

Surface Mount

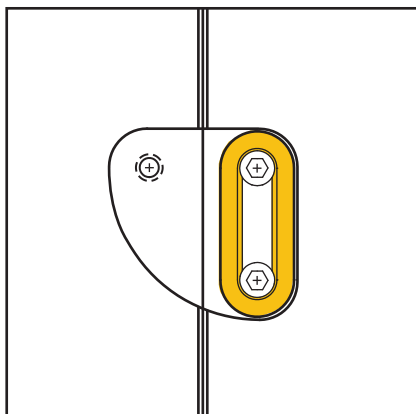

Swing Mount

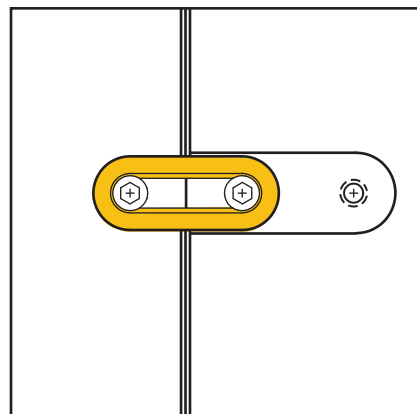

Sliding Mount

EXAMPLE MOLD SIZES	STRAP PART NUMBER
UNDER 1,000 LBS (UNIT DIES AND 8X8 AND SMALLER)	SAFT-88
UNDER 1,500 LBS (EX. 15 7/8 x 26)	SAFT-150
UNDER 3,000 LBS (EX. 19 1/2 x 35 1/2)	SAFT-200



Unlike other mold straps, Progressive's Safety Straps have an engineered break point to avoid bolt shearing when left on the tool in the press.